



APOLLO™ HI-RISER™ MONITOR STYLE 3433/3431 INSTALLATION, OPERATING, AND MAINTENANCE INSTRUCTIONS

The following is intended to provide the basic instructions for installation, operation and maintenance of the Apollo Hi-Riser DImonitor and the Apollo Hi Riser SI monitor, and to assist in attaining the best possible performance from the unit. Read and understand these operating instructions before use.

PRODUCT RATINGS:

Maximum flow : 1250 gpm in the deck mode
: 800 gpm while operating in the ground base - Dual Inlet
: 1000 gpm while operating in the ground base - Single Inlet
Maximum Pressure : 200 psi

PRODUCT WARNINGS:

- ⚠ **WARNING:** For fire fighting use only by trained fire fighters.
- ⚠ **WARNING:** Charge the unit slowly. Rapid charging may cause a pressure surge which has the potential to cause an injury, or damage the monitor.
- ⚠ **WARNING:** Aim the unit in a safe direction before pumping water through it (i.e. away from power lines).
- ⚠ **WARNING:** Replace the identification tags if they should become worn or damaged.
- ⚠ **WARNING:** While operating in the direct mount flange base or portable base, **THE TWO CONNECTING PINS MUST BE FULLY ENGAGED AT ALL TIMES.**
- ⚠ **WARNING:** Read and follow the Warning Tag Instructions on the lock pin lanyard.
- ⚠ **WARNING:** **NEVER OPERATE THE UNIT IN THE RAISED POSITION WHILE IN THE GROUND BASE.**
- ⚠ **WARNING:** **DO NOT** exceed the maximum pressure or flow ratings of the monitor. Exceeding these ratings may lead to an injury or may cause damage to the monitor.
- ⚠ **WARNING:** **DO NOT** install shutoffs on the outlet of the Apollo Hi-Riser monitor. Shutoffs increase the potential for pressure surges due to water hammer, which have the potential to cause an injury or damage the monitor.
- ⚠ **WARNING:** If not equipped with the automatic drain valve, drain the Apollo Hi-Riser monitor after use to prevent “freeze damage.”
- ⚠ **WARNING:** Ensure the thread on the nozzle swivel matches the thread on the monitor outlet. Do not over tighten the nozzle onto the unit.

MONITOR ATTACHMENT:

- ⚠ **WARNING:** **INSUFFICIENT STRUCTURAL SUPPORT CAN LEAD TO FAILURE, WHICH HAS POTENTIAL TO CAUSE INJURY. THEREFORE, ADDITIONAL STRUCTURAL SUPPORT AT THE INLET FLANGE ON THE VEHICLE DECK MAY BE REQUIRED.** (Contact Akron Brass Customer Service for assistance.)

⚠WARNING: Do not install the Hi-Riser onto any elevating deck gun device including but not limited to:
1. The Akron Brass Upper Deck; 2. The TFT® Extend-A-Gun™; 3. The Elkhart Pipe™.

To install the direct mount flange, keep in mind that the rating for this monitor is 1250 gpm maximum flow and 200 psi maximum operating pressure. The reaction force generated by these ratings is 900 lbs at the outlet. The outlet can be 23.6" high when in the elevated position. Therefore, the support at the flange must be capable of safely supporting a torque of 1,770 ft-lbs.

To install the monitor onto either the direct mount flange base or the portable base, place the monitor onto the appropriate base so that the holes in the ears are aligned. Then insert one lock pin at a time through the holes in the ears. **MAKE SURE BOTH PINS ARE FULLY ENGAGED BEFORE OPERATING.**

To remove the monitor from either the direct mount flange base or the ground base, hold the monitor securely by the carry handle and pull each lock pin straight out

OPERATING INSTRUCTIONS:

The hand wheel and the brake knob are used to control the monitor. To change the horizontal monitor position toward the "RIGHT" or "LEFT", turn the brake knob counterclockwise until the unit can be easily rotated. Turn the same knob to the right to lock the unit in the desired horizontal position. To change the vertical monitor position upward or downward, turn the hand wheel clockwise or counterclockwise until it is aimed in the desired direction.

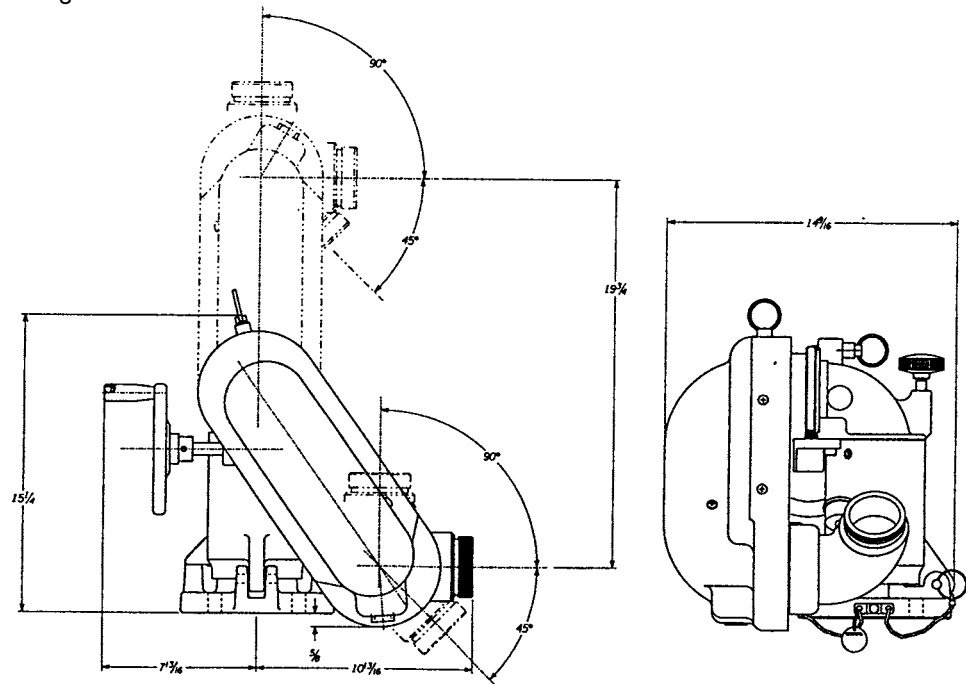

To raise the unit for operation over obstructions first make sure that the unit is properly installed on the direct mount deck flange and that NO water is flowing through the unit. With one hand, pull the ring for the release pin on the top of the elevating arm with the other hand grab hold and pull up on the outlet end of the elevating arm until the release pin clicks in place. NOTE: If the unit is difficult to elevate, turn the handwheel to relieve pressure on the elevation stop.

To lower the unit for storage or ground base operation first make sure no water is flowing through the unit. With one hand pull the ring for the release pin on the bottom of the elevating arm and with the other hand grab hold and push down on the outlet end of the elevating arm until the release pin clicks in place.

⚠When changing from direct mount flange base to the ground base, be sure that the elevating arm is in the lowered position, the outlet elbow is above the 35° vertical safety stop, and that all folding legs are fully deployed on the ground base before use. This is essential for proper stability in the portable mode.

WARNING: DO NOT OPERATE THE UNIT IN THE RAISED POSITION WHILE IN THE GROUND BASE.
An adjustable safety chain with hook is provided in the front of the ground base as an additional safety precaution. Connect the hook to rigid stationary object such as a parking meter, manhole, car wheel, etc., in front of the unit, and pull the chain tight. **DO NOT OPERATE THE UNIT IN THE PORTABLE BASE WITHOUT THE SAFETY CHAIN SECURED.** To release the hook and/or lengthen the chain, hold the spring loaded latch open and pull the chain through the eye of the hook.

STYLE 3433 DUAL INLETGROUND BASE: IMPORTANT INSTRUCTIONS FOR USINGTHE STYLE 3433APOLLO HI-RISERMONITOR ON CONCRETEANDOTHERHARD SURFACES:

When the Apollo Hi-Riser monitor is used with the dual inlet ground base on concrete, each spike must be “set” with the head of the safety hook, a 16 oz. Hammer or equivalent. After the Apollo is hooked up and ready to flow, set the spikes in rotation by striking the hex head bolt over each ground spike with a sharp blow from a hammer or another tool sufficient to drive the spike at least 1/8” (3mm) into the concrete. This process must be repeated each time the unit is repositioned on a concrete surface. As with any portable monitor, the Apollo Hi-Riser should always be secured with the safety chain or ropes before using on any surface.

⚠CAUTION: Wear safety glasses or face shield when setting the spikes. The chain and/or ropes will stretch when charging the unit. Ensure that you stand clear when charging. If the unit moves, reset the spikes.

The portable base is designed to grip by imbedding the ground spikes into the surface on which it is operating. These spikes will not grip on metal, marble, or similar hard surfaces. Do not operate on these surfaces without securing the unit with rope or some other stable means, in addition to the safety chain.

The ground spikes in the portable base are made of a special hardened tool steel to remain sharp through extended use. If, after use, the flats on the ends of the spikes exceed 1/16” (1.5mm) diameter, the spikes must be sharpened or replaced. (SeeMaintenance Instructions).

Each spike must be in uniform contact with ground surface at all times during use. Make sure that no large rocks or other debris are under the portable base during use, for this may cause the spikes to come out of contact with the ground surface. The maximum safe operating pressure for this unit is 200 PSI. (1400kPa).

The Apollo Hi-Riser monitor is designed with a safety stop at 35° above horizontal to maintain stability when used in the portable base. Do not release the elevation stop and operate below that point unless the unit is secured in the direct mount base.

⚠WARNING: Read and follow the safety chain warning tag located on the groundmount tag.

⚠WARNING: Read and follow the plunger pin caution tag.

GROUND BASE SETUPINSTRUCTIONS:

- Rotate legs to the full open position.
- Aim center leg toward target.
- Ensure the unit is in the lowered position.
- Set spikes with hammer.
- Ensure Lock pins are fully engaged.
- Aim discharge upward.
- Secure safety chain.
- Charge hose slowly.
- If unit moves while charging, reset spikes.

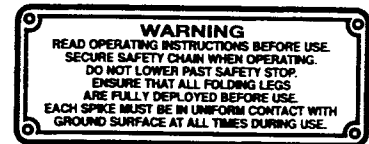

When used in the DI portable base, the unit should not be operated at more than 500 gpm (1900 lpm) with one hose and 800 gpm (3030 lpm) with two hoses. Therefore, do not exceed the following discharge pressures with straight tips unless the unit is secured in the direct mount flange base:

Figure 1

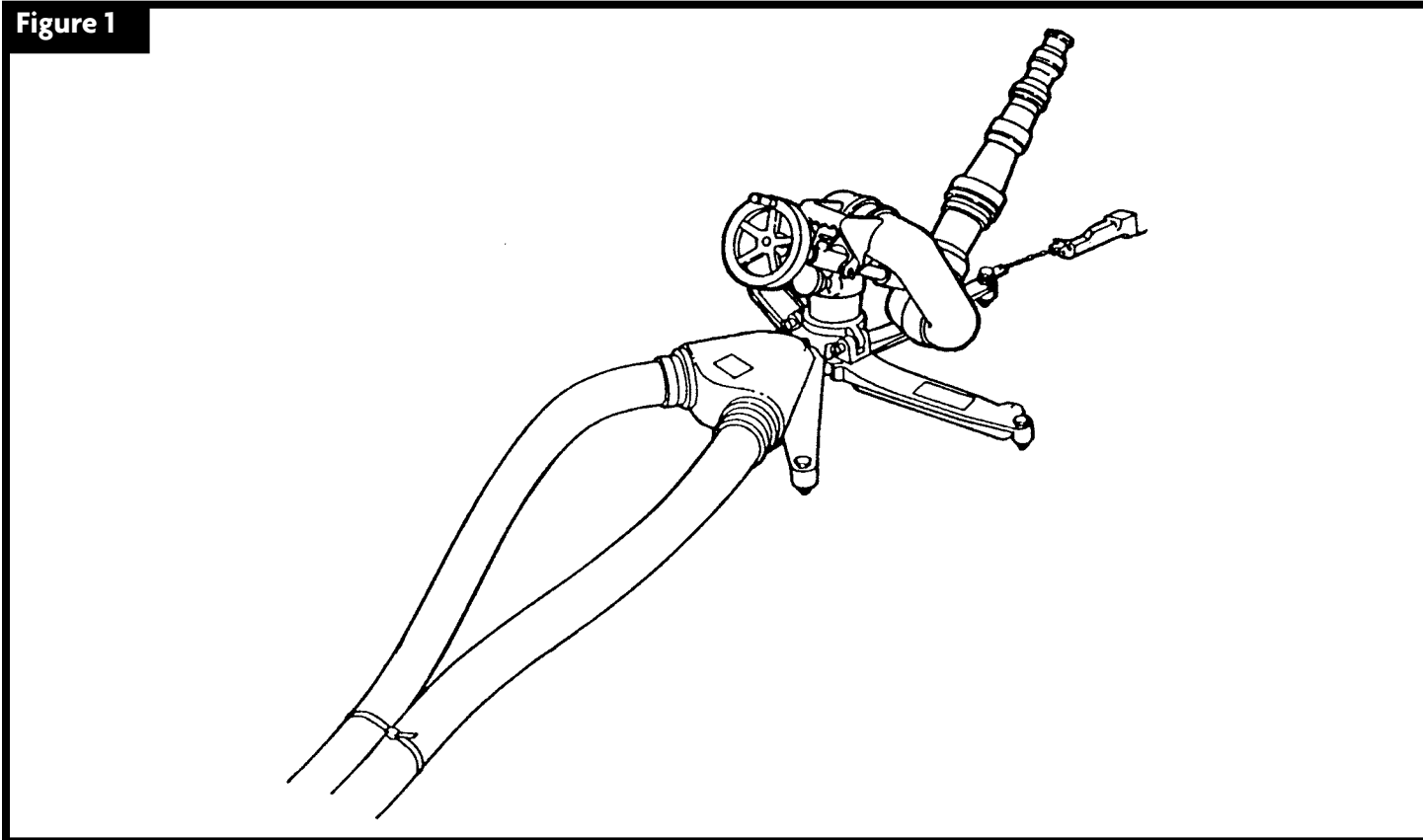

TIP SIZE	TWO HOSES		ONE HOSE	
	PSI	kPa	PSI	kPa
1- ³ / ₈ "	100	690	75	515
1- ¹ / ₂ "	100	690	55	380
1- ³ / ₄ "	70	480	NR	NR
2"	50	345	NR	NR

(NR - not recommended)

Do not exceed 500 gpm (1900 lpm) with one hose and 800 gpm (3030 lpm) with two hoses, when using a fog nozzle, unless the unit is secured in the direct mount flange base.

⚠️WARNING: Read and follow the tip pressure tag located on the groundmount tag.

The following hose arrangement is recommended for this appliance (See Figure 1): Use two hoses and bring both hoses straight back from the siamese parallel to each other. Loosely tie the hoses together 10 ft. (3m) from the monitor with a hose and ladder strap, rope, etc.

⚠️WARNING: Incorrect hose layout may cause instability.

⚠️CAUTION: Do not use larger than 3" diameter hose.

When the unit is operating in the portable base, do not attempt to move or pick up any part of the base itself or the 10 feet (3m) of supply hose closest to the unit.

When the unit is stored in the direct mount base or truck mount, it is recommended that the elevating arm be placed in the lowered position and the nozzle or tips be lowered against a rigid support or removed during transportation.

**STYLE 3431 SINGLE INLETGROUND BASE:
IMPORTANT INSTRUCTIONS FOR USINGTHE STYLE 3431APOLLO HI-RISER S.I. ON
CONCRETEAND OTHER HARD SURFACES:**

When the Apollo HI Riser S.I. monitor is used with the portable base on concrete, each spike must be “set” with the head of the safety hook, a 16 oz. hammer or equivalent. After the Apollo is hooked up and ready to flow, set the spike in rotation by striking the hex head bolt, over each ground spike, with a sharp blow from a hammer or another tool sufficient to drive the spike at least 1/8” (3mm) into the concrete. this process must be repeated each time the unit is repositioned on a concrete surface. As with any portable monitor, the Apollo should always be secured with the safety chain or ropes before using on any surface.

⚠CAUTION: Wear safety glasses or face shield when setting the spikes. The portable base is designed to grip by imbedding the ground spike into the surface on which it is operating.

These spikes will not grip on metal, marble, or similar hard surfaces. Do not operate on these surfaces without securing the unit with rope or some other stable means, in addition to the safety chain.

The ground spikes in the portable base are made of a special hardened tool steel to remain sharp through extended use. If, after use, the flats on the ends of the spike exceed 1/16” (1.5mm) diameter, the spikes must besharpened or replaced. (SeeMaintenance Instructions.)

Each spike must be in uniform contact with ground surface at all times during use.Make sure that no large rocks or other debris are under the portable base during use, for this may cause the spikes to come out of contact with the ground surface. The maximum safe operating pressure for this unit is 200 PSI. (1400 kPa), in the direct mount base.

The Apollo S.I.Monitor is designed with a safety stop at 35° above horizontal to maintain stability when used in the portable base. Do not release the elevation stop and operate below that point unless the unit is secured in the direct mount base.

⚠WARNING - Read and Follow The Safety ChainWarning Tag Located On The GroundMount Tag.

⚠WARNING- **ReadAnd Follow The Plunger Pin Caution Tag.**
For use with 4”, 4-1/2” or 5” hose only.

When used in the portable base, the unit should not be operated at more than 1000 GPM(3800 LPM). Therefore, do not exceed the following discharge pressures with straight tips unless the unit is secured in the direct mount flange base:

TIP SIZE	PSI	kPa
1-3/8”	100	690
1-1/2”	100	690
1-3/4”	100	690
2”	75	515

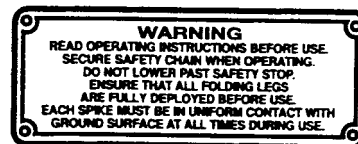

Also, do not exceed 1000 GPM(3800 LPM) when using a fog nozzle, unless the unit is secured in the direct mount flange base. Be sure the storz or swivel is attached securely.

⚠WARNING - Read And Follow The Tip Pressure Tag Located On The GroundMount Tag. THE FOLLOWING HOSE SET-UPMUST BE USED TO PROVIDE NECESSARY STABILITYWHEN OPERATING THE STYLE 3411/3413.

⚠WARNING - ReadAnd Follow The Set-Up Instructions Tag Located On Inlet Body

⚠WARNING - Incorrect Hose LayoutMay Cause Instability.

SETUP INSTRUCTIONS:

Aim center leg toward target.

Slide buckles to end of tie down straps.

Connect straps loosely around hose.
DO NOT tighten.

Set spikes with hammer.

Ensure lock pins are fully engaged. Aim discharge upward.

Secure safety chain.

Charge hose slowly.

Tighten straps around hose until it contacts hose stop.

If unit moves while charging, reset spikes.

When the unit is operating in the portable base do not attempt to move or pick up any of the base itself, the hose loop, or the 10 feet (3m) of straight hose ahead of the hose loop.

When the unit is stored in direct mount base or truck mount, it is recommended that the nozzle or tips be lowered against a rigid support or removed during transportation.

⚠ CAUTIONS:

Your Apollo Hi-Riser monitor and nozzle should be inspected prior to and after each use to ensure it is in good operating condition. Periodically, an unanticipated incident occurs where the unit is misused in a manner that is inconsistent with standard operating practices. A partial list of potential misuses includes:

- Operating above maximum rated pressure or flow.
- Prolonged exposure to temperatures above 140°F, or below -40°F.
- Operating in a corrosive environment.
- Other misuse that might be unique to your specific environment.

Also, there are many “tell tale” signs that indicate repair is in order, such as:

- A hand wheel that is inoperable or difficult to operate.
- Excessive wear.
- Poor discharge performance.
- Water leaks.

If any of the above situations are encountered, the Apollo Hi-Riser monitor should be taken out of service, repaired, and tested by a qualified technician before placing back in service.

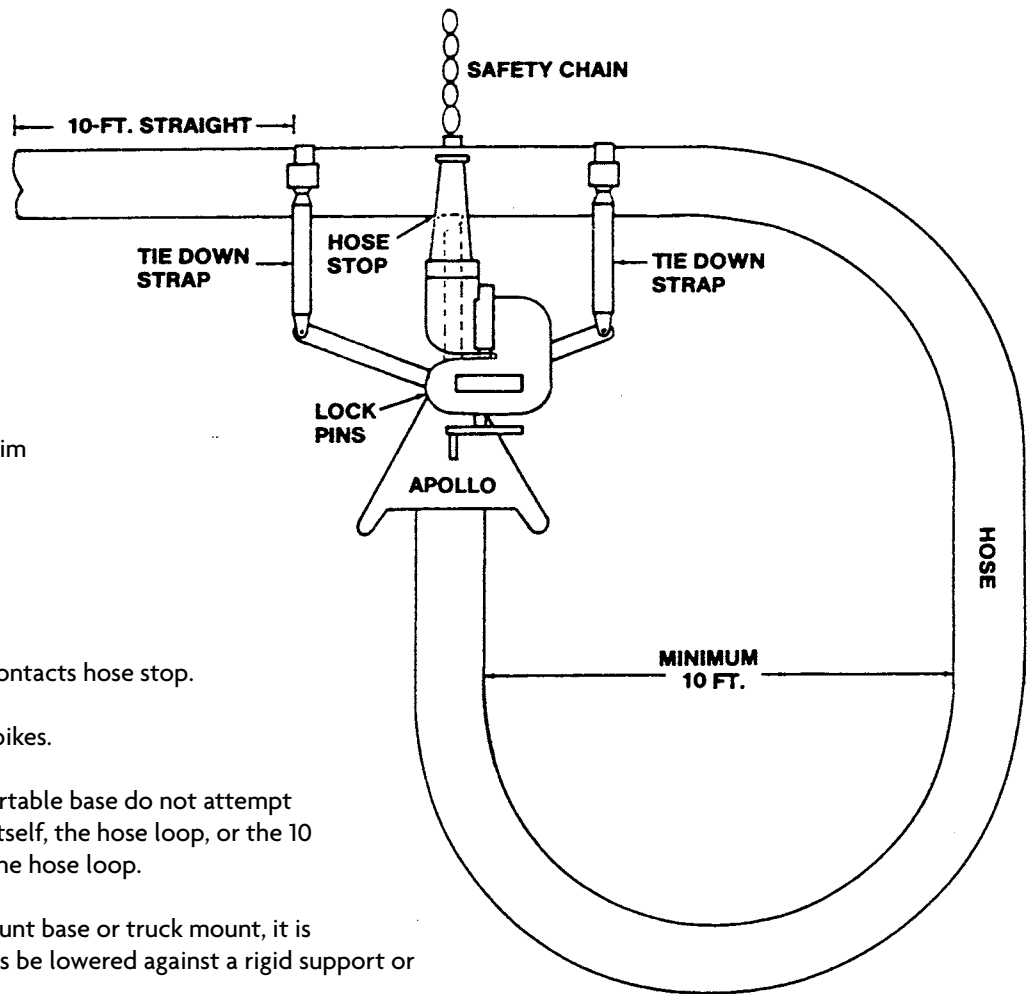

ROUTINE MAINTENANCE INSTRUCTIONS

Style 3433/3431 Apollo Hi-Riser Portable Monitor

The following maintenance procedures will prolong the proper operation of this appliance.

LUBRICATION: Three grease fittings are provided for periodic lubrication. Use Low-Temp Lubriplate or equivalent. The horizontal swivel joint and the outlet elbow joint should be lubricated until a small amount of grease appears through the holes in the swivel plugs on either side of the grease fittings.

⚠ CAUTION - Avoid excessive pressure when using the grease gun. This may damage the O-ring seals in the joints.

The elevating mechanism must be lubricated in two places - the elevation worm gear should have grease applied periodically and the elevation chain should be periodically oiled on the exposed areas. It may be necessary to adjust the elevation while oil is being applied to the chain to ensure lubrication of the full chain length.

Oil should also be applied periodically to the handwheel shaft, the two plunger pins, and the upper gear bearing. The bearing surface can be oiled through two access holes in the gear.

Examine the points of the ground spikes in the portable base. If the flat of any spike exceeds $\frac{1}{16}$ " (1.5mm) diameter, it must be sharpened or replaced. To sharpen, use a flat file or grinder and maintain the same taper as the original spikes. If a grinder is used, do not allow the spikes to become hot, or change color, since this will reduce the hardness and spikes will not remain sharp in service.

Check the spring loaded spike holders in the portable base to ensure that they move freely. Use a dry spray lubricant if lubrication is required.

Check that the elevation stop operates properly and must be released to lower the unit below 35° elevation.

Check that both inlet clappers function properly on dual inlet bases. Lubrication is not normally required in this area.

Check that the horizontal brake operates freely and apply a small amount of oil to the brake shaft.

Check that the latch of the safety chain hook engages properly in the chain.

If any parts do not function properly, contact Akron Brass for repair instructions or return the unit to the Akron Brass Company.



Tested.. Proven.. Trusted.

ISO 9001 REGISTERED COMPANY

PHONE: 330.264.5678 or 800.228.1161 | FAX: 330.264.2944 or 800.531.7335 | akronbrass.com

REVISED: 6/18

WARRANTY AND DISCLAIMER: We warrant Akron Brass products for a period of five (5) years after purchase against defects in materials or workmanship. Akron Brass will repair or replace product which fails to satisfy this warranty. Repair or replacement shall be at the discretion of Akron Brass. Products must be promptly returned to Akron Brass for warranty service.

We will not be responsible for: wear and tear; any improper installation, use, maintenance or storage; negligence of the owner or user; repair or modification after delivery; damage; failure to follow our instructions or recommendations; or anything else beyond our control. WE MAKE NO WARRANTIES, EXPRESS OR IMPLIED, OTHER THAN THOSE INCLUDED IN THIS WARRANTY STATEMENT, AND WE DISCLAIM ANY IMPLIED WARRANTY OF MERCHANTABILITY OR FITNESS FOR ANY PARTICULAR PURPOSE. Further, we will not be responsible for any consequential, incidental or indirect damages (including, but not limited to, any loss of profits) from any cause whatsoever. No person has authority to change this warranty.

© Akron Brass Company. 2018 All rights reserved. No portion of this can be reproduced without the express written consent of Akron Brass Company.



STYLE 3433 HI-RISER INDICATOR LIGHT INSTALLATION AND OPERATING INSTRUCTIONS

The Hi-Riser Indicator Light is designed to indicate when the Apollo Hi-Riser monitor is stowed or deployed.

INSTALLATION INSTRUCTIONS

A. BRACKET

Position Mounting Bracket in desired location. Mount Bracket using the appropriate configuration (See Figure 1). Rotate Bracket until Indicator Unit is under outlet elbow in the stowed position. Tighten bracket down securely using the two $\frac{5}{8}$ bolts and the four $\frac{5}{8}$ nuts and washers.

B. MAGNET

Line up bottom of Magnet Bracket to corner of Outlet Elbow. (See Figure 2). Drill two (.166, drill size 19) diameter holes $\frac{1}{2}$ " to $\frac{3}{4}$ " deep. Install self-tapping screws. Test if location of magnet is appropriate. Apply a drop of Loctite to each screw.

NOTE: Apply Loctite only when hole has been fully tapped and magnet operates correctly in placed position.

C. WIRING

Connect the three conductor cables to the appropriate connections.

White: Cab Light

Red: Vehicle Battery Positive

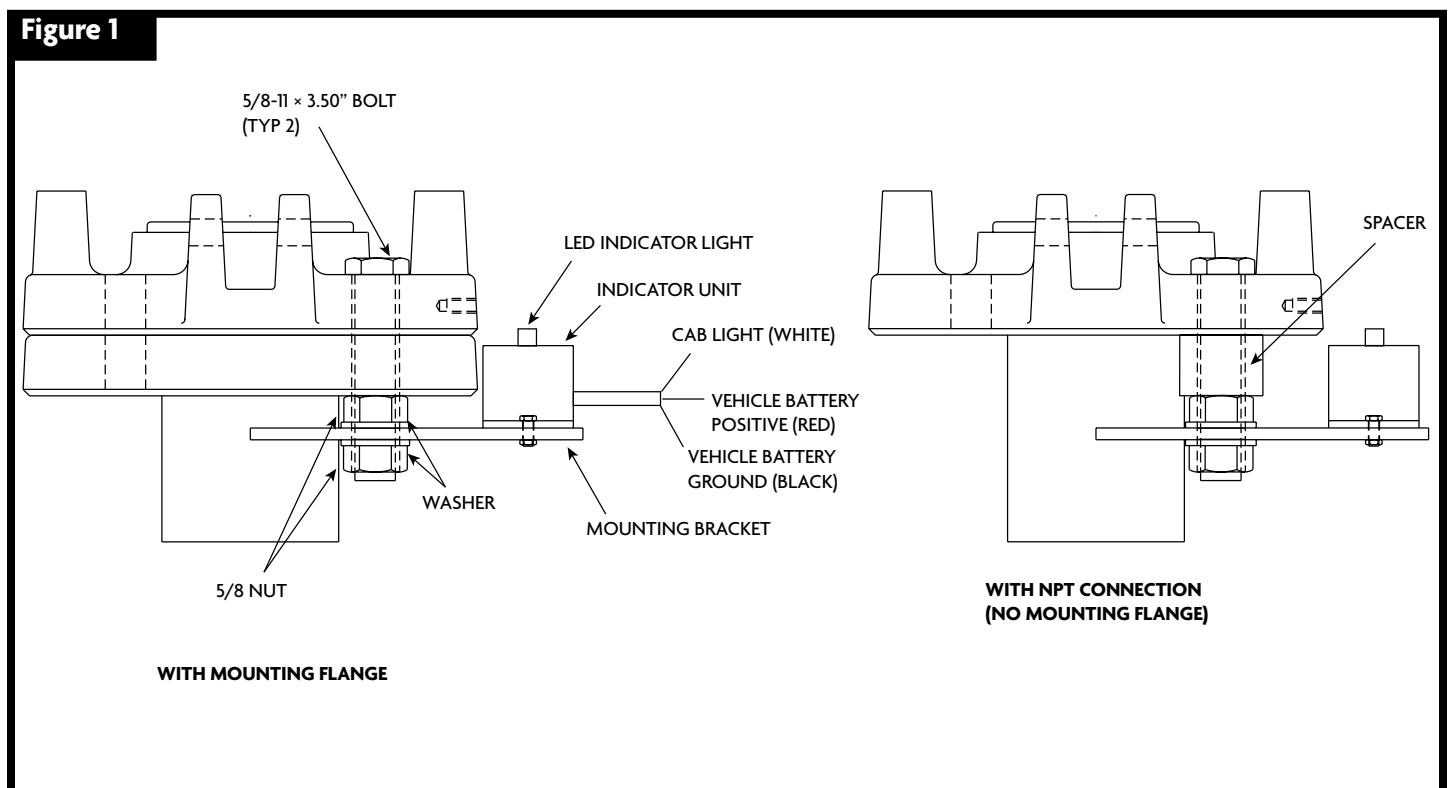
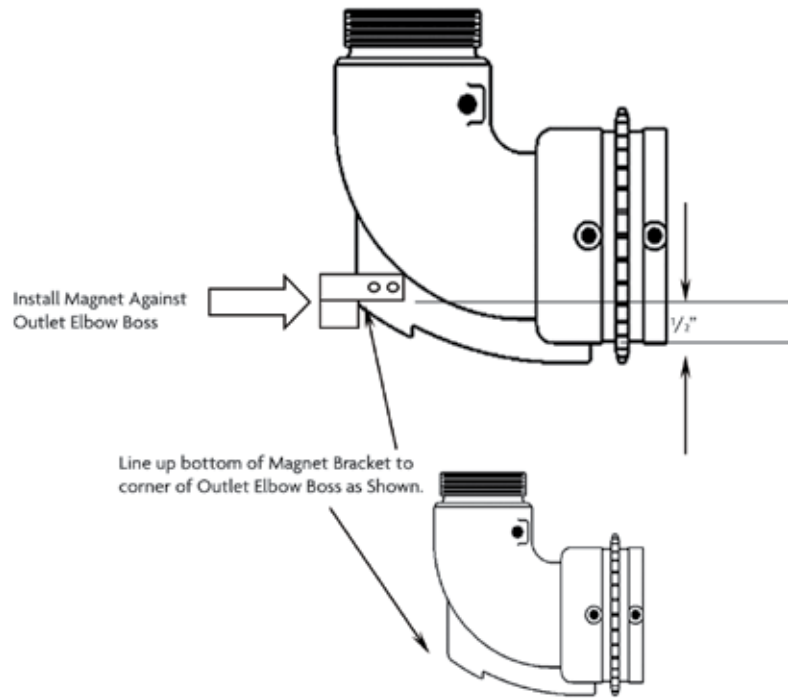

Figure 2



Black: Vehicle Battery Ground

OPERATING INSTRUCTIONS

A. DEPLOY

When the monitor is in the deployed position, the LED Indicator Light and the corresponding Cab Light will turn on.

B. STOW

Stow the monitor and rotate the unit until the outlet elbow is above the Indicator Unit. Position the monitor until the LED Indicator Light turns off and lock the horizontal rotation using the brake knob. The corresponding Cab Light will also turn off.



Tested—Proven—Trusted.

ISO 9001 REGISTERED COMPANY

PHONE: 330.264.5678 or 800.228.1161 | FAX: 330.264.2944 or 800.531.7335 | akronbrass.com

REVISED: 11/11

WARRANTY AND DISCLAIMER: We warrant Akron Brass products for a period of five (5) years after purchase against defects in materials or workmanship. Akron Brass will repair or replace product which fails to satisfy this warranty. Repair or replacement shall be at the discretion of Akron Brass. Products must be promptly returned to Akron Brass for warranty service.

We will not be responsible for: wear and tear; any improper installation, use, maintenance or storage; negligence of the owner or user; repair or modification after delivery; damage; failure to follow our instructions or recommendations; or anything else beyond our control. WE MAKE NO WARRANTIES, EXPRESS OR IMPLIED, OTHER THAN THOSE INCLUDED IN THIS WARRANTY STATEMENT, AND WE DISCLAIM ANY IMPLIED WARRANTY OF MERCHANTABILITY OR FITNESS FOR ANY PARTICULAR PURPOSE. Further, we will not be responsible for any consequential, incidental or indirect damages (including, but not limited to, any loss of profits) from any cause whatsoever. No person has authority to change this warranty.

© Akron Brass Company, 2011 All rights reserved. No portion of this can be reproduced without the express written consent of Akron Brass Company.



Apollo Ground Base Spike Caps Installation Instructions

To attach the Spike Caps to the Apollo Ground Base

Drill and Tap two holes with $\frac{1}{4}$ -20 thread on the two folding legs. See Figure 1 for location. Attach one Spike Cap and Lanyard Assembly to each leg with the $\frac{1}{4}$ -20 screw supplied.

To store the Apollo Ground Base

Fold the legs in first, cover the spike with the Spike Cap and slower push until snug. See Figure 2. If the Cap is loose, remove the Cap from the Spike and gently squeeze the ends until a suitable fit.

To remove the Spike Caps upon deployment

Simply pull the folding legs out into the deployed position. See Figure 3. The Spike Cap will be pulled off the Spike.

Caution: Ensure the Spike Cap is removed from the Spike before Flowing water through the Apollo Monitor.

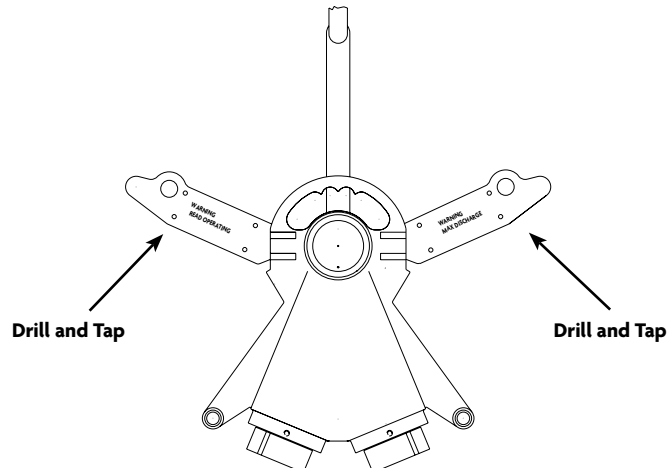

Figure 1



Figure 2



Figure 3



Tested.. Proven.. Trusted.

ISO 9001 REGISTERED COMPANY

PHONE: 330.264.5678 or 800.228.1161 | FAX: 330.264.2944 or 800.531.7335 | akronbrass.com

REVISED: 8/11

WARRANTY AND DISCLAIMER: We warrant Akron Brass products for a period of five (5) years after purchase against defects in materials or workmanship. Akron Brass will repair or replace product which fails to satisfy this warranty. Repair or replacement shall be at the discretion of Akron Brass. Products must be promptly returned to Akron Brass for warranty service.

We will not be responsible for: wear and tear; any improper installation, use, maintenance or storage; negligence of the owner or user; repair or modification after delivery; damage; failure to follow our instructions or recommendations; or anything else beyond our control. WE MAKE NO WARRANTIES, EXPRESS OR IMPLIED, OTHER THAN THOSE INCLUDED IN THIS WARRANTY STATEMENT, AND WE DISCLAIM ANY IMPLIED WARRANTY OF MERCHANTABILITY OR FITNESS FOR ANY PARTICULAR PURPOSE. Further, we will not be responsible for any consequential, incidental or indirect damages (including, but not limited to, any loss of profits) from any cause whatsoever. No person has authority to change this warranty.

© Akron Brass Company, 2011 All rights reserved. No portion of this can be reproduced without the express written consent of Akron Brass Company.

Chg.	Date
21	01-16
22	08-21

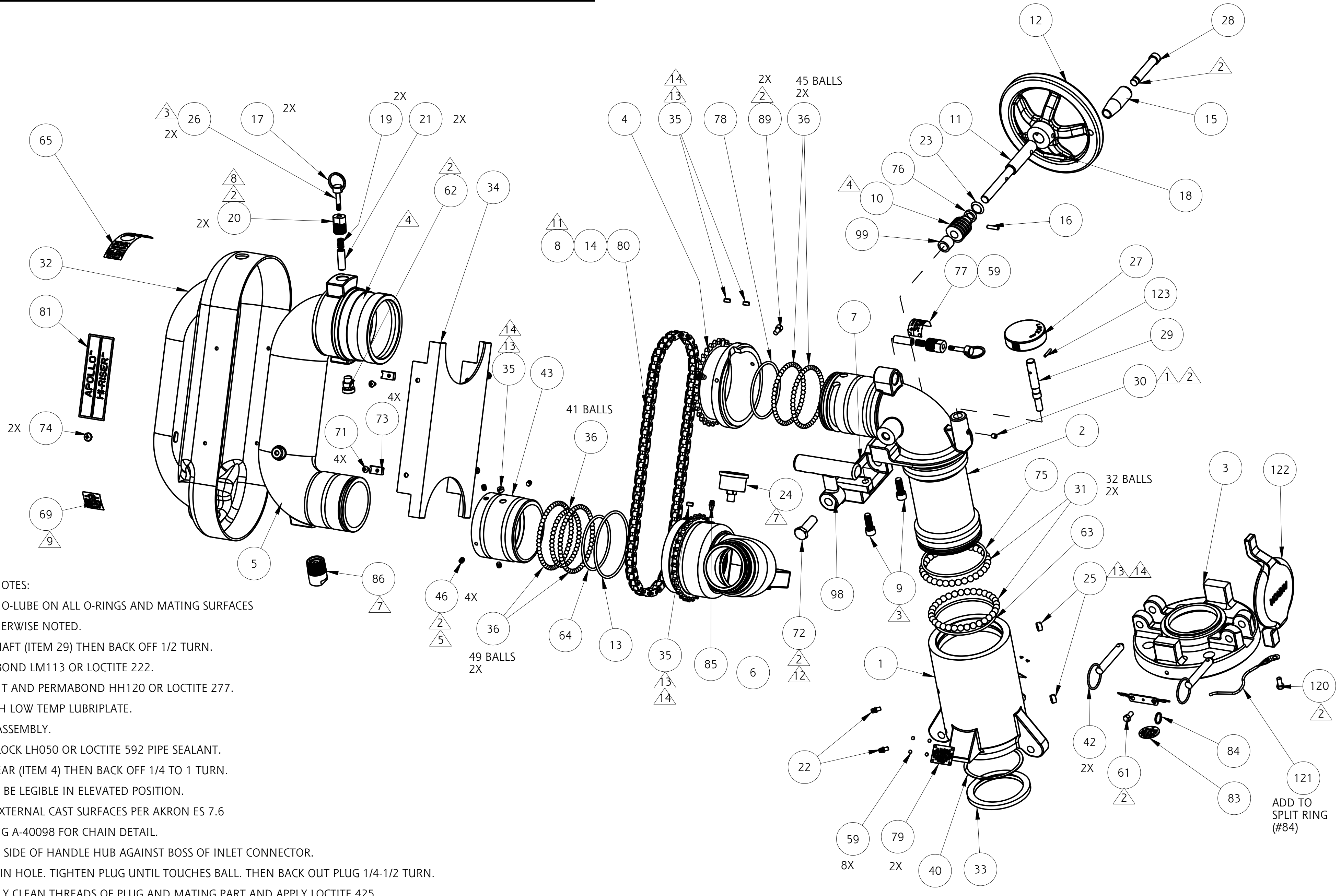

ASSEMBLY NOTES:
USE PARKER O-LUBE ON ALL O-RINGS AND MATING SURFACES UNLESS OTHERWISE NOTED.

- 1 CONTACT SHAFT (ITEM 29) THEN BACK OFF 1/2 TURN.
- 2 USE PERMABOND LM113 OR LOCTITE 222.
- 3 USE PRIMER T AND PERMABOND HH120 OR LOCTITE 277.
- 4 GREASE WITH LOW TEMP LUBRIPLATE.
- 5 DIMPLE AT ASSEMBLY.
- 7 USE PERMALOCK LH050 OR LOCTITE 592 PIPE SEALANT.
- 8 CONTACT GEAR (ITEM 4) THEN BACK OFF 1/4 TO 1 TURN.
- 9 LABEL MUST BE LEGIBLE IN ELEVATED POSITION.
- 10 PAINT ALL EXTERNAL CAST SURFACES PER AKRON ES 7.6
- 11 SEE DRAWING A-40098 FOR CHAIN DETAIL.
- 12 PLACE LONG SIDE OF HANDLE HUB AGAINST BOSS OF INLET CONNECTOR.
- 13 ALIGN BALL IN HOLE. TIGHTEN PLUG UNTIL TOUCHES BALL. THEN BACK OUT PLUG 1/4-1/2 TURN.
- 14 THOROUGHLY CLEAN THREADS OF PLUG AND MATING PART AND APPLY LOCTITE 425.

PHONE: 800.228.1161 | www.akronbrass.com

WARRANTY AND DISCLAIMER*: We warrant Akron Brass products for a period of five (5) years* after purchase against defects in materials or workmanship. Akron Brass will repair or replace product which fails to satisfy this warranty. Repair or replacement shall be at the discretion of Akron Brass. Products must be promptly returned to Akron Brass for warranty service. We will not be responsible for: wear and tear; any improper installation, use, maintenance or storage; negligence of the owner or user; repair or modification after delivery; failure to follow our instructions or recommendations; or anything else beyond our control. WE MAKE NO WARRANTIES, EXPRESS OR IMPLIED, OTHER THAN THOSE INCLUDED IN THIS WARRANTY STATEMENT, AND WE DISCLAIM ANY IMPLIED WARRANTY OF MERCHANTABILITY OR FITNESS FOR ANY PARTICULAR PURPOSE. Further, we will not be responsible for any consequential, incidental or indirect damages (including, but not limited to, any loss of profits) from any cause whatsoever. No person has authority to change this warranty. *Unless otherwise provided herein. Akron Brass industrial electronic components & the Severe-Duty Monitor have a one (1) year warranty. Select Akron Brass handline nozzles and valves carry a ten (10) year warranty. Scene Star Lights carry a (6) year warranty. Weldon products have a two (2) year warranty from date of manufacture (excluding consumable components). Select Weldon LED products carry a five (5) year warranty. Honda products have the manufacturers' warranty and Akron Brass disclaims any warranty in respect of those products.

© 2016 Akron Brass Company. All rights reserved. No portion of this can be reproduced without the express written consent of the Akron Brass Company.

Parts List Sheet:
104441



TECHNICAL SERVICE PARTS

STYLE 3433

PRODUCT APOLLO HI-RISER

IF AN ITEM IS NOTED AS "NOT FIELD REPAIRABLE", OR YOU WISH TO RETURN AN ITEM TO AKRON BRASS FOR SERVICE PLEASE GO ONLINE TO, ONLINEREPAIR.AKRONBRASS.COM

Chg.	Date
21	01-16
22	08-21

FIND	DESCRIPTION	P/N	QTY
1	INLET CONNECTOR	109865	1
2	ELBOW INLET	109864	1
4	UPPER GEAR	109856	1
5	MAIN ELBOW	109863	1
6	OUTLET ELBOW	109855	1
7	GEAR HOUSING	109862	1
8	ROLLER CHAIN	707364	1
9	SCREW 3/8 -16 X 1"	767047	2
10	WORM GEAR	784190	1
11	HANDWHEEL SHAFT	768279	1
12	HANDWHEEL	109016	1
13	O-RING 2-241	757210	1
14	CONNECTING LINK	729339	1
15	HANDLE	721204	1
16	ROLL PIN 3/16 X 3/4	744068	1
17	SPLIT RING	758130	2
18	ROLL PIN 1/4 X 1-1/2	744076	1
19	PLUNGER SPRING	768150	2
20	PLUNGER HOUSING	721318	2
21	PLUNGER PIN	744363	2
22	GREASE FITTING 1/4	713192	2
23	SPRING WASHER	768199	1
24	GAUGE	718322	1
25	CELCON PLUG	742123	2
26	PLUNGER SCREW	765184	2
27	KNOB	109189	1
28	HANDLE PIN	744220	1
29	BRAKE SHAFT	768278	1
30	SET SCREW 1/4 -20X1/4"	765002	1
31	* Ø 3/8 BALL BRASS	-	64
32	OUTER COVER	707362	1
33	VEE GASKET	714173	1
34	INNER COVER	707363	1
35	** SWIVEL PLUG	-	4
36	** Ø 1/4 BALL BRASS	-	229
40	RETAINING RING	758216	1
43	ECCENTRIC SPACER	109857	1
46	SET SCREW 1/4 -20 X 3/8	765108	2
59	NAIL GRIP	736052	12
62	STOP SCREW	766054	1
63	O-RING 2-239	757222	1
64	O-RING 2-235	757046	1
65	PLUNGER WARNING LABEL	729336	1
69	WARNING LABEL	729337	1
71	SCREW PHILLIPS #10AX1/2	763074	4
72	SCREW 1/2 -13 X 1 1/2	761085	1

FIND	DESCRIPTION	P/N	QTY
73	NUT	735055	4
74	SCREW PHILLIPS 1/4-20 X 1/4"	763076	2
75	O-RING 2-240	757017	1
76	WORM SPACER	770279	1
77	LEVER WARNING PLATE	744364	1
78	O-RING 2-236	757035	1
79	LIFTOFF WARNING PLATE	744365	2
80	OFFSET LINK	729340	1
81	HI-RISER LABEL	729338	1
85	GREASE FITTING	713204	1
89	SCREW 1/4 -20 X 3/8"	766043	2
98	HANDLE	109873	1
99	SPACER	769562	1
120	ROLL PIN 1/8 X 3/4"	744066	1
3	FLANGE MOUNT HIGH RISE	109537	1
42	LANYARD ASSEMBLY	109258	2
61	SCREW 1/4-20 X 1/2	761066	1
83	LOCK PIN TAG	773135	1
84	SPLIT RING	758142	1
86	DRAIN VALVE	34330009	1
120	SCREW 1/4-20 X 1/2	761066	1
121	10" LANYARD	729117	1
123	ROLL PIN	744066	1

* KIT OF 50 BALLS: 109342
 ** KIT OF 50 BALLS: 109041

PHONE: 800.228.1161 | www.akronbrass.com

WARRANTY AND DISCLAIMER*: We warrant Akron Brass products for a period of five (5) years* after purchase against defects in materials or workmanship. Akron Brass will repair or replace product which fails to satisfy this warranty. Repair or replacement shall be at the discretion of Akron Brass. Products must be promptly returned to Akron Brass for warranty service. We will not be responsible for: wear and tear; any improper installation, use, maintenance or storage; negligence of the owner or user; repair or modification after delivery; failure to follow our instructions or recommendations; or anything else beyond our control. WE MAKE NO WARRANTIES, EXPRESS OR IMPLIED, OTHER THAN THOSE INCLUDED IN THIS WARRANTY STATEMENT, AND WE DISCLAIM ANY IMPLIED WARRANTY OF MERCHANTABILITY OR FITNESS FOR ANY PARTICULAR PURPOSE. Further, we will not be responsible for any consequential, incidental or indirect damages (including, but not limited to, any loss of profits) from any cause whatsoever. No person has authority to change this warranty. *Unless otherwise provided herein. Akron Brass industrial electronic components & the Severe-Duty Monitor have a one (1) year warranty. Select Akron Brass handline nozzles and valves carry a ten (10) year warranty. Scene Star Lights carry a (6) year warranty. Weldon products have a two (2) year warranty from date of manufacture (excluding consumable components). Select Weldon LED products carry a five (5) year warranty. Honda products have the manufacturers' warranty and Akron Brass disclaims any warranty in respect of those products.

© 2016 Akron Brass Company. All rights reserved. No portion of this can be reproduced without the express written consent of the Akron Brass Company.

Parts List Sheet:

104441